

3803

120° Snap-On 3000 Series



- Heat tempered, all-metal construction
- Three-dimensional adjustment in hinge arm
- Automatic smooth-closing design for minimal abrasion and wear
- Accommodates overlays up to 19mm (3/4")
- Reduces door installation time by 50%
- Undue stress absorbed through self-tightening action

3803/3804 Minimum Reveal (measured in millimeters)

Door thickness

Cup drilling distance	16	17	18	19	20	21	22
3.0-4.5	1.4	1.7	2.0	2.4	4.1	5.8	7.6
5.0	1.2	1.6	1.9	2.1	2.5	3.8	5.6

Ordering Information

Packaging:

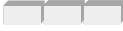
300 pieces 

(50 pieces per interior box)

*300 bulk

For baseplate selection, refer to pages 64-66.

IMPORTANT

To determine the correct application, Grass strongly recommends a trial mounting for all hinges and baseplates.

	Screw-On Hinge Cup		Dowelled Hinge Cup	
	Description	Item #	Description	Item #
3803 Overlay	- self-closing	3803 VS	3803 VS8	70042
	- self-closing		3803 VS8-45	27839*
	- free-swinging	3813 VS	3813 VS8	12343
3804 Half-Overlay	- self-closing	3804 VS	3804 VS8	12638
	- self-closing		3804 VS8-45	27840*
	- free-swinging	3814 VS	3814 VS8	12639
Cover Cap		3803 (black plastic)	12350	Packaging: 50 pieces (Imprinting available)
		3803 (nickel plastic)	12351	Packaging: 50 pieces (Imprinting available)
		3804 (black plastic)	55409	Packaging: 50 pieces (Imprinting available)
		3804 (nickel plastic)	55410	Packaging: 50 pieces (Imprinting available)

VS = vertical steel cup, VS8 = vertical steel cup with two 8mm dowels, VS8-45 = vertical steel cup with two 8mm dowels in 45mm boring pattern

3803 Overlay

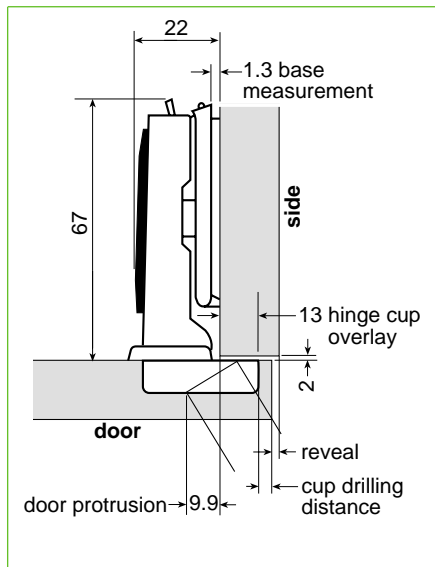

3804 Half-Overlay

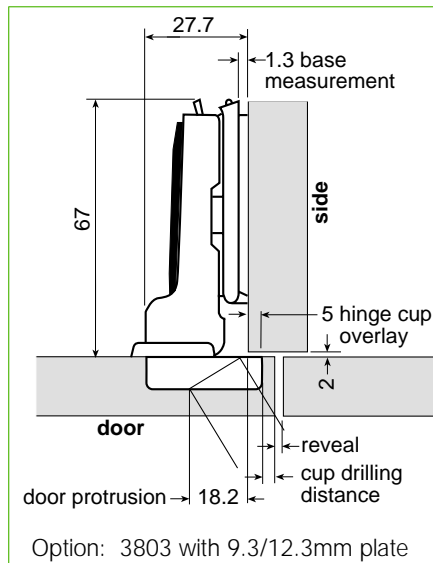

Maximum Door Thickness and Overlay

Maximum Door Overlay:
18mm (23/32") in a neutral position
on a 1.3mm baseplate.

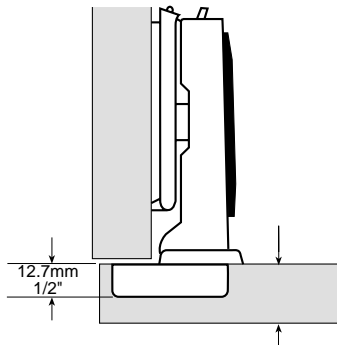

Maximum Door Thickness:
16mm (5/8") - 22mm (7/8") overlay

Cup Drilling

Cup Drilling Depth: 12.7mm (1/2")
Cup Drilling Distance: 3mm (1/8") to
5mm (3/16"), depending on end panel
thickness and overlay desired.

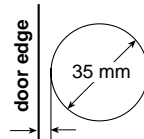

Hinge Adjustments

- ① Side Adjustment +/-2mm
- ② Depth Adjustment ... +/-2mm
- ③ Height Adjustment . +/-2mm

Note: Use a POZIdrive screwdriver
for hinge adjustment.

Fastening Screws #6 x 5/8" FHP

